



Corrosion Control and Cathodic Protection Data Sheet

CORROSION CONTROL

Corrosion control is the application of engineering principles and procedures to minimise corrosion to an acceptable level by the most economical method. It is rarely practical or economical to eliminate corrosion completely and in practice, one or more of the following methods would be applied.

For corrosion to occur, all of the following conditions must be present:

- There must be a cathode
- There must be an anode
- There must be a metallic path connecting the anode and the cathode.
- There must be a conducting electrolyte surrounding both the anode and the cathode.

The anode is the area at which oxidation or corrosion occurs where the current leaves the metal to enter the electrolyte.

The cathode is the area at which reduction or negligible corrosion occurs where the current leaves the electrolyte to enter the metal.

The electrolyte is a solution in which the conduction of electric current occurs by the passage of dissolved ions.

When the above conditions are met, an electric current will flow and metal will be consumed at the anode, i.e. the anode corrodes. Should any one of these conditions be removed, then corrosion will be prevented.

CATHODIC PROTECTION

Corrosion occurs when an electric current (corrosion current) flows from the metal surface into the electrolyte at the anodic areas and onto the metal surface from the electrolyte at the cathodic areas.

It is possible to make every part of the metal surface cathodic. This can be done by applying an external current from a power supply using an anode that will not easily corrode (impressed current cathodic protection), or by using a material that is electrically more negative to deliberately create a galvanic corrosion cell where all the corrosion takes place on a piece of metal (sacrificial anode) that is not structurally significant.

In practice, the direct current is forced to flow from a source, external to the metal surface, onto all the metal surfaces. When the amount of current is properly adjusted, it will overcome corrosion current discharging from all the anodic areas on the metal and there will be a net current flow onto the protected surface at these points. The entire surface will then be cathodic and full protection achieved.

Pipeline Maintenance Limited

Cathodic Protection Engineering and Materials Supply
11 & 12 Merlin Park, Mildenhall,
Suffolk, IP28 7RD, UK
Tel: +44 (0) 1638 711955
Fax: +44 (0) 1638 711953

Data Sheet CC&CP Rev 01

Page No 1 of 7

email: sales@pipelinemaintenance.co.uk
website: www.pipelinemaintenance.co.uk



This is shown diagrammatically below:

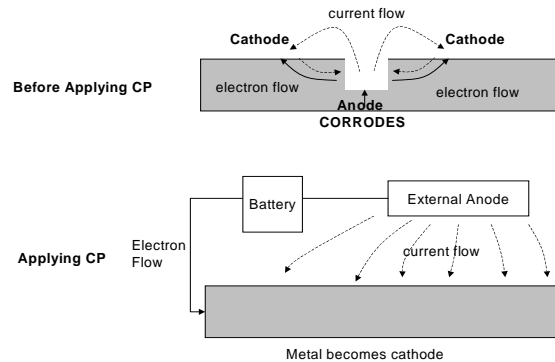

If, as shown in figure, current is to be forced onto the metal at areas which were previously anodic, the driving voltage of the cathodic protection system must be greater than the driving voltage of the corrosion cells being overcome.

The original cathodic areas on the metal received current from the anodic areas. Under cathodic protection, these same cathodic areas will receive even more current. Note the metal that has corroded is not restored.

In order for the cathodic protection system to work, the current is discharged from an external anode. In discharging the current, the anode is subject to corrosion. Because the sole purpose of the external anode is to discharge current, it is desirable to use materials which are consumed at a low rate. The corrosion cell still exists with cathodic protection, but the corrosion at the anode is transferred from the structure being protected to the external anode.

There are two methods used for applying cathodic protection that are based on the power source used, namely Galvanic or Impressed Current. Galvanic anodes utilise the potential difference between the steel and the more anodic material to provide the driving voltage. Impressed current utilises an external DC voltage source to drive the current through relatively inert anodes.

Galvanic anodes have the advantage of requiring no external source of power; have low maintenance requirements other than routine checks on potentials achieved and no running costs. System life can be extended by installing replacement anodes and unforeseen areas of high current demand can be accommodated by the installation of extra anodes close to these areas.

Impressed current systems provide a wider range of anode types and, because an external power source is used, they offer a more controllable power output, such that if a greater driving voltage is required the output can be increased. Typically the power source is from a local a.c. power feed. The a.c. is transformed to a lower voltage, for example from 240V to 48V and rectified to provide the d.c. output required. For this reason the power supply unit is often known as a transformer rectifier or TR.

Pipeline Maintenance Limited

Cathodic Protection Engineering and Materials Supply

11 & 12 Merlin Park, Mildenhall,
Suffolk, IP28 7RD, UK

Tel: +44 (0) 1638 711955

Fax: +44 (0) 1638 711953

Data Sheet CC&CP Rev 01

Page No 2 of 7

email: sales@pipelinemaintenance.co.uk

website: www.pipelinemaintenance.co.uk





Corrosion Control and Cathodic Protection

Cathodic protection can only be applied to steel surfaces buried in the soil, immersed in water, or cast into concrete i.e. where it is fully surrounded by an electrolyte. Steel in the air will not receive cathodic protection and must rely on a protective coating (e.g. coating) for corrosion protection.

It is essential for the protected structure to be fully electrically continuous for cathodic protection to be effectively applied. High resistive connections will restrict the amount of current afforded to the structure section affected and where continuity does not exist may create interaction effects which can cause corrosion.

When cathodic protection is applied to a metal surface (cathode) a chemical reaction takes place. This reaction can cause a scale or deposit to be formed. This deposit increases the electrical resistance of the circuit, which can result in a reduction in protective current. Consequently the current required to initially achieve cathodic protection is more than that required to maintain protection once polarisation has been achieved.

Combined Coatings & Cathodic Protection

The economic incentive for applying corrosion protection to a buried pipeline is relatively easy to demonstrate. Corrosion of steel in soil is characterised by irregular attack (pitting rather than thinning). Pitting rates vary widely, but average about 25 microns a year for all soils. Thus, to provide a corrosion allowance for a 20 year life in average soil, the thickness of line pipe must be increased by about 5 mm. The installed cost of extra metal to cater for this corrosion allowance would be approximately 6/10 times greater than the cost of a good coating applied on a pipeline, which is the primary defence against corrosion. However, coatings are not perfect and deteriorate with age and should be complemented with cathodic protection. The savings made are more than adequate to cover the installation and operation of a cathodic protection system over the life of the pipeline.

Studies conducted over the years have shown that the leak rate increases exponentially with time for lines not cathodically protected. A properly selected coating of good materials and applied with reasonable care will make cathodic protection much more effective even if some damage to the coating develops. A poorer coating requires more current for protection and can result in subjecting the coating to excessively negative potentials at the point where current is drained from the pipeline in order to provide adequate protective potentials further along the line. In other words, attenuation of potential is more pronounced under these circumstances.

In summary, the better the quality of coating produced on a pipeline, the lower the level of current needed in a cathodic protection system to adequately afford full protection of a pipeline.

Pipeline Maintenance Limited

Cathodic Protection Engineering and Materials Supply

11 & 12 Merlin Park, Mildenhall,
Suffolk, IP28 7RD, UK

Tel: +44 (0) 1638 711955

Fax: +44 (0) 1638 711953

Data Sheet CC&CP Rev 01

Page No 3 of 7

email: sales@pipelinemaintenance.co.uk

website: www.pipelinemaintenance.co.uk





Corrosion Control and Cathodic Protection

CATHODIC PROTECTION CRITERIA

To ensure that structures are effectively protected, structure-to-electrolyte potentials should be maintained at the levels stated below:

Minimum Potentials for Cathodic Protection (Volts)				
Reference Electrode and conditions of use				
Copper/Copper Sulphate(in soils and fresh water)	Aerobic	- 0.850	Anaerobic	- 0.950
Silver/Silver Chloride (Sea Water)	Aerobic	- 0.800	Anaerobic	- 0.900
Zinc (Sea Water)	Aerobic	+ 0.250	Anaerobic	+ 0.150

(Table 1: BS 7361-1:1991 Cathodic protection. Part 1. Code of practice for land and marine applications)

Pipeline Maintenance Limited

Cathodic Protection Engineering and Materials Supply

11 & 12 Merlin Park, Mildenhall,
Suffolk, IP28 7RD, UK

Tel: +44 (0) 1638 711955

Fax: +44 (0) 1638 711953

Data Sheet CC&CP Rev 01

Page No 4 of 7

email: sales@pipelinemaintenance.co.uk

website: www.pipelinemaintenance.co.uk



GLOSSARY

A list of common corrosion terminology:

Active	A state in which a metal tends to corrode (opposite of passive).
Aeration Cell	An oxygen concentration cell, an electrolytic cell resulting from differences in dissolved oxygen at two points.
Anaerobic	An absence of unreacted or free oxygen.
Anode	(Opposite of cathode). The electrode at which oxidation or corrosion occurs.
Aqueous	Pertaining to water; an aqueous solution is a water solution.
Bimetallic Corrosion	Corrosion resulting from dissimilar metal contact also known as galvanic corrosion.
Cathode	(Opposite of anode). The electrode where reduction (and practically no corrosion) occurs.
Cathodic Polarisation	Polarisation of the cathode, a change from the initial potential resulting from current flow effects at or near the cathode surface. Potential becomes more active (negative) because of cathodic polarisation.
Cathodic Protection	Reduction or elimination of corrosion by making the metal a cathode by causing a DC current to flow. Either by impressing a DC current or by attaching a sacrificial anode (usually Mg, Al, or Zn).
Cell	A circuit consisting of an anode and a cathode in electrical contact in a soil or liquid electrolyte. Corrosion generally occurs only at anodic areas.
Corrosion	The destruction of a substance, usually a metal, or its properties because of a reaction with its surroundings (environment).
Corrosion Fatigue	The combined action of corrosion and fatigue (cyclic stressing) causing metal fracture.
Corrosion Potential	The potential that a corroding metal exhibits under specific conditions of concentration, time, temperature, aeration, velocity, etc.
Couple	A cell developed in an electrolyte resulting from electrical contact between two dissimilar metals.
Current Density	The current per unit area generally expressed as milliamps per square centimetre (mA/cm^2) (also amps per square metre or milliamps per square foot etc).



Corrosion Control and Cathodic Protection

Depolarisation	The elimination or reduction of polarisation by physical or chemical means. Depolarisation results in increased corrosion.
Differential Aeration Cell	An oxygen concentration cell (a cell resulting from a potential difference caused by different amounts of oxygen dissolved at two locations).
Electrode	A metal in contact with an electrolyte which serves as a site where an electrical current enters the metal or leaves the metal to enter the solution.
Electrode Potential	The potential of an electrode as measured against a reference electrode.
Electrolysis	Chemical changes in an electrolyte caused by an electrical current. The use of this term to mean corrosion by stray currents is discouraged.
Electrolyte	An ionic conductor (usually in aqueous solution).
Erosion	Deterioration of a surface by the abrasive action of moving fluids. This is accelerated by the presence of solid particles or gas bubbles in suspension. When deterioration is further increased by corrosion, the term erosion-corrosion is often used.
Galvanic Cell	A cell consisting of two dissimilar metals in contact with each other and with a common electrolyte (sometimes refers to two similar metals in contact with each other but with dissimilar electrolytes; differences can be small and more specifically defined as a concentration cell).
Galvanic Corrosion	Corrosion that is increased because of the current caused by a galvanic cell (sometimes called couple action).
Galvanic Series	A list of metals arranged according to their relative corrosion potentials in some specific environment, seawater is often used.
Half Cell	Commonly, a plastic tube with a porous end, usually containing a copper rod or wire in a solution of copper sulphate. Alternatively, a silver rod or wire is used in a solution of silver chloride. A portable half cell or reference electrode is used to measure the potential of the structure under test. Technically, a half-cell is a pure metal in contact with a solution of known concentration of its own ion. At a specific temperature, the half-cell develops a potential, which is characteristic and reproducible.
Holiday	A discontinuity (hole or gap) in a protective coating.
Local Action	Corrosion due to action of local cells, i.e., galvanic cells caused by non-uniformity between two adjacent areas at a metal surface exposed to an electrolyte.

Pipeline Maintenance Limited

Cathodic Protection Engineering and Materials Supply
11 & 12 Merlin Park, Mildenhall,
Suffolk, IP28 7RD, UK
Tel: +44 (0) 1638 711955
Fax: +44 (0) 1638 711953

Data Sheet CC&CP Rev 01

Page No 6 of 7

email: sales@pipelinemaintenance.co.uk
website: www.pipelinemaintenance.co.uk





Corrosion Control and Cathodic Protection

Local Cell	A galvanic cell caused by small differences in composition in the metal or the electrolyte.
Open Circuit Potential	The measured potential of a cell in which no current flows.
Over Voltage	The difference in electrode potential when a current is flowing compared with when there is no current flow; also known as polarisation.
Over Protection	A term used to the excessive application of cathodic protection current that may damage the protective coating
Oxidation	Loss of electrons, as when a metal goes from the metallic state to the corroded state (opposite of Reduction). Thus, when a metal reacts with oxygen, sulphur, etc., to form a compound as oxide, sulphide, etc., it is oxidised.
Passivation	A reduction of the anodic reaction rate of an electrode involved in electrochemical action such as corrosion.
pH	A measure of the acidity or alkalinity of a solution. A value of seven is neutral, low numbers are acid, large numbers are alkaline. Strictly speaking, pH is the negative logarithm of the hydrogen ion concentration.
Polarisation	The shift in electrode potential resulting from the effects of current flow.
Protective Potential	A term sometimes used in Cathodic Protection to define the minimum potential required to suppress corrosion. For steel in seawater, this is claimed to be about 0.85 Volts as measured against a saturated calomel reference electrode.
Reduction	Gain of electrons, as when copper is electroplated on steel from a copper sulphate solution (opposite of Oxidation).
Rusting	Corrosion of iron or an iron base alloy to form a reddish-brown product, which is primarily hydrated ferric oxide.
Sacrificial Protection	The suppression or prevention of corrosion of a metal in an electrolyte by galvanically coupling it to a more anodic metal.
Stray Current	Current that emanates from a source external to the structure under protection. Examples are DC traction railways, cathodic protection from other structures, geomagnetic currents.
Stray Current Corrosion	Corrosion that is caused by stray current from some external source.
Under-protection	Term used to imply that insufficient current is being applied to provide full suppression of corrosion

Pipeline Maintenance Limited

Cathodic Protection Engineering and Materials Supply

11 & 12 Merlin Park, Mildenhall,
Suffolk, IP28 7RD, UK

Tel: +44 (0) 1638 711955

Fax: +44 (0) 1638 711953

Data Sheet CC&CP Rev 01

Page No 7 of 7

email: sales@pipelinemaintenance.co.uk

website: www.pipelinemaintenance.co.uk

